

M407 - SPI Interface

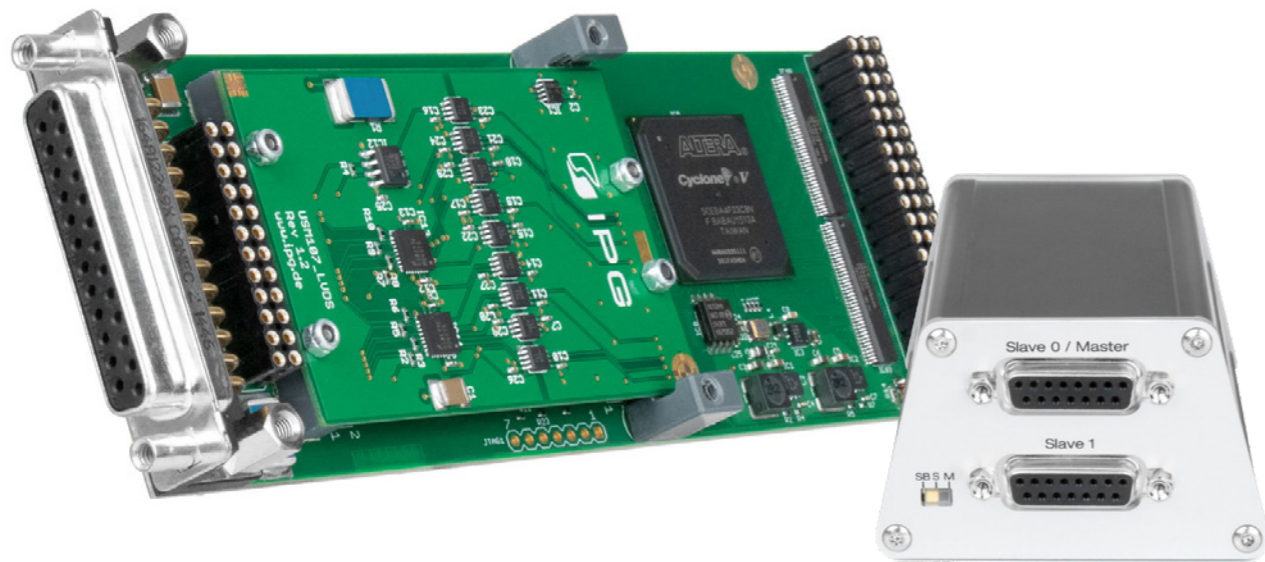

Features

- 5 slaves controllable by master channel
- Reduction of EMI and maximization of baud rate by use of Adaption Box
- Communication between M407 and Adaption Box via LVDS
- Maximum SPI clock frequency:
Slave 12MBaud; Master: 20MBaud
- Several SPI sensor emulations available, e.g. Bosch SMA550 / SMA560

Use Cases

- Emulating standard or custom SPI based sensors like gyroscopes, accelerometers, and temperature sensors
- Providing 1 master or 2 slave SPI communication channels to interface any SPI component

Block Diagram

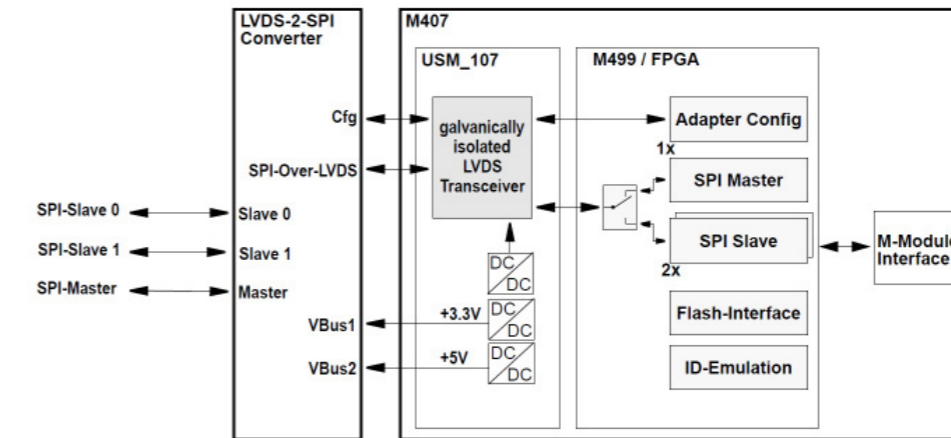

Technical Data

Channels	1 master or 2 slaves, configurable
Supported communication modes	<ul style="list-style-type: none"> • Simple SPI controller • Mail box mode (addressable registers) • Several special sensor emulation modes. Please ask IPG for further details.
Maximum baud rate	<ul style="list-style-type: none"> • Slave: 0 .. 12MBaud • Master: 0 .. 20MBaud
Number of bits per frame	128
Bus voltage	Bus voltage is compatible to 3.3V and 5V SPI-busses
Overvoltage protection	24V (implemented in the adaption box)
Supply current	5V / 700mA
Address space	A08 and A24
Connectors	2x 15pin SubD, female (Adaption Box)
Scope of Delivery	M-Module M07, LVDS2SPI Box, LVDS Cable
The M407 itself is an SPI over LVDS module. To generate real SPI signals the external signal adaptation box (LVDS2SPI converter) has to be used. The LVDS2SPI converter and the cable are included in the delivery.	

Order Information

Order Number	IO-M407
--------------	---------

Alternatives

M405	For LIN communication interfaces
M410	For CAN FD communication interfaces
M406	For PSI5 communication interfaces
M414	For SENT communication interfaces