

## M414 – SENT/SPC Interface

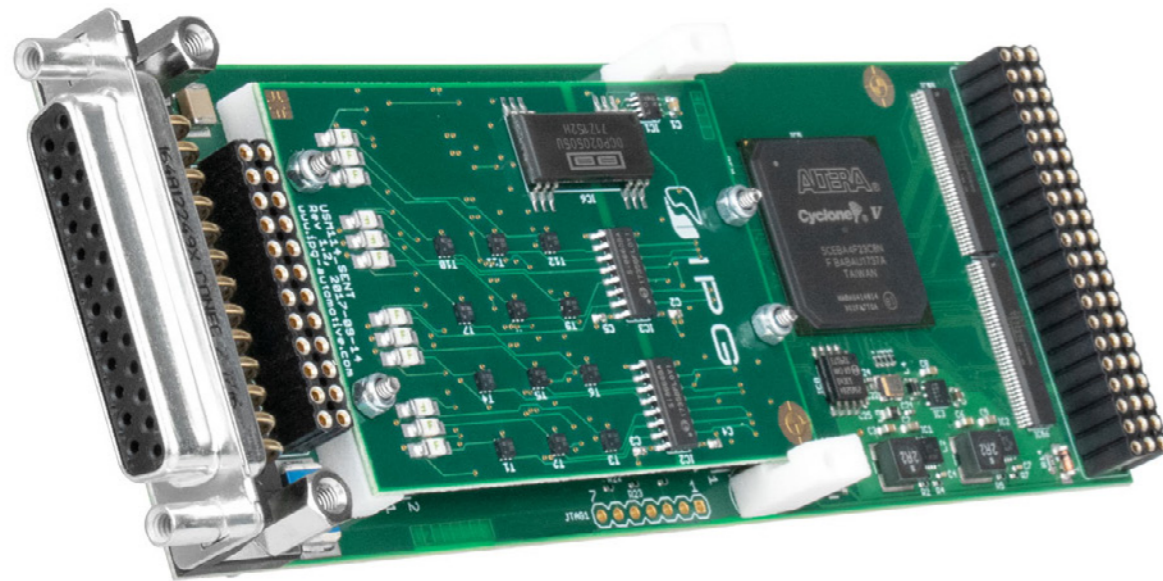

### Features

- 12 SENT Transceiver Channels
- Supports SENT and SPC (Short PWM Code)
- Minimum Ticktime less than 0.5 us
- Data length selectable from 1 to 6 nibbles
- Support for optional pause pulse
- Transmitter
  - Asynchronous transmission of frames
  - Manually triggered transmission of frames
  - Receiver-triggered transmission of frames (SPC)
  - Hardware calculation of CRC (legacy or recommended mode)
  - Optional user defined CRC
  - Automatic generation of serial data messages
- Receiver
  - Automatic data rate synchronization
  - Detection of CRC errors
  - FIFO for buffering up to 32 data frames
  - Automatic extraction of serial data from the data frames

### Use Cases

- Simulation of intelligent sensors with SENT protocol
- Simulation of intelligent sensors with SPC protocol
- Testing of intelligent sensors with SPC/SENT protocol
- Sniffing on SENT Busses

### Block Diagram

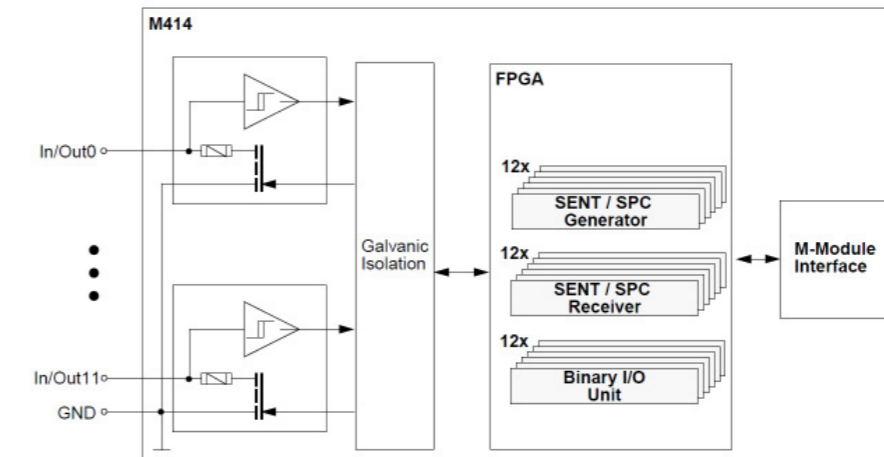

### Technical Data

SENT channels	12 combined receiver/transmitter channels
Maximum voltage	40VDC
Maximum current	Fused at 500mA
Low level output voltage	≤ 0.2V
High level output voltage	Defined by external pullup
Low level input voltage	≤ 0.8V
High level input voltage	≥ 1.3V
Minimum tick time	≤ 0.5 μs
Temperature range	-10° ...+60 degrees C
Power consumption from MM-Bus	5V: 100mA and 12V: 200mA
Address space needed	A08D16 and A24D32

### Order Information

Order Number	IO-M414
--------------	---------

### Alternatives

M405	For LIN communication interfaces
M406	For PSI5 communication interfaces
M407	For SPI based sensor emulations
M410	For CAN FD communication interfaces